

A-1F Broiler / Griddle Combination

Specifications:

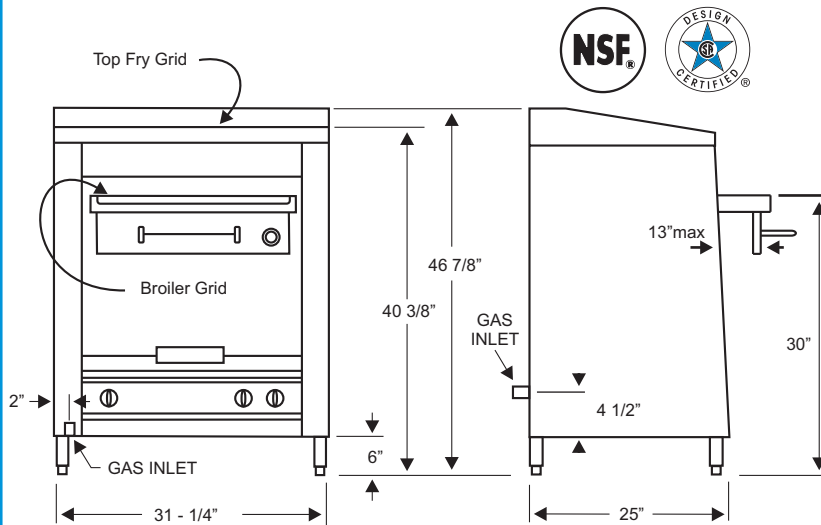

Overall Width:	31 1/4"
Overall Depth (body):	25"
Overall Height:	46 7/8"
Top Fry Grid Height:	40 3/8"
Broiler Grid Up:	30"
Broiler Grid Down:	26"
Legs (S/S) :	6"
Broiler Grid pulls out:	13"
Broiler Grid:	17 3/4" x 23 1/2"
Top Fry Grid:	20" x 31"
Gas Inlet:	3/4" pipe
Maximum BTU:	102,000
Crated Weight (approx):	500 lbs.

- Heavily insulated, all stainless steel body with stainless steel inner body lining and stainless steel removable side and back liners for easier cleaning
- All welded frame with stainless steel legs and adjustable feet
- Cast iron top burners with ceramic radiants
- Broiler griddle mechanism assembly removable for easier cleaning
- Broiler mechanism moves in and out with ease on our specially designed, heavy-duty ball bearing rollers for loading and unloading of product

Product Specifications:

Body:	18 Gauge #304 Stainless Steel
Inner Liner:	24 Gauge #304 Stainless Steel
Griddle Plates:	Top -- 1/2" Highly Polished Steel Plate Bottom -- 5/8" Highly Polished Steel Plate
Splash:	14 Gauge #304 Stainless Steel
Burners:	Top -- Cast Iron w/Ceramic Radiants Bottom -- Stainless Steel
Drip Pan:	18 Gauge #304 Stainless Steel
Valves:	Heavy Duty Brass
Gas Inlet:	3/4 NPT
Gas Pressure:	4.0" Natural, 11.0" Propane (Inches Water Column)

Available Options:

- Casters (6" Locking)
- Casters w/Extension Legs (adds 6" to all vert. dimensions)
- Long Legs - Stainless Steel (adds 6" to all vert. Dimensions)

Notes:

Gas Pressure Regulator is supplied and must be installed
 Combustible Locations: 6" Clearance sides and back
 Non-Combustible Locations Only: 0" Clearance sides and back
 Specify type of gas and altitude if over 2,000 feet

Connerton reserves the right, without notice, to make changes and revisions in product specifications, materials and design, which in our opinion will provide better performance, durability and efficiency.

Connerton

Telephone: (714) 547-9218

Fax: (714) 547-1969



Model A-1F Broiler / Griddle Combination

Date: Project: Quantity:

Cooks In Half The Time

Cooking both sides simultaneously

Additional Griddle On Top

Maximizes floor and hood space

#304 Stainless Steel Body

Both interior and exterior



(shown with optional casters with extension legs)



The Model A-1F has Connerton’s unique “Over/Under Broiling System”. Heat is applied to both sides of the product simultaneously by two sets of burners. One set is under the broiling griddle which is thermostatically controlled. The other set is above the broiling griddle and is an infrared type, producing a penetrating heat. The top griddle receives it’s heat from the broiler top burners; one set of burners doing two jobs.

With the A-1F every job is done in half the time. Shrinkage is dramatically reduced due to the product being subjected to heat only half as long. Since the heat is applied to both sides of the product simultaneously, natural juices are sealed in. There is no need to turn the product while cooking, and grease is not needed.

Capital investment is reduced because a Connerton will give you more output in half the floor and ventilator hood space. A Connerton can be used for every meal in any operation. Even more important, guests will experience shorter wait times for a better tasting meal.

Connerton

5199 E. Pacific Coast HWY Suite# 310 Long Beach, CA 90804

Telephone: (714) 547-9218 Fax:(714) 547-1969

www.connertoncooking.com