

# A-1F BROILER / GRIDDLE COMBINATION

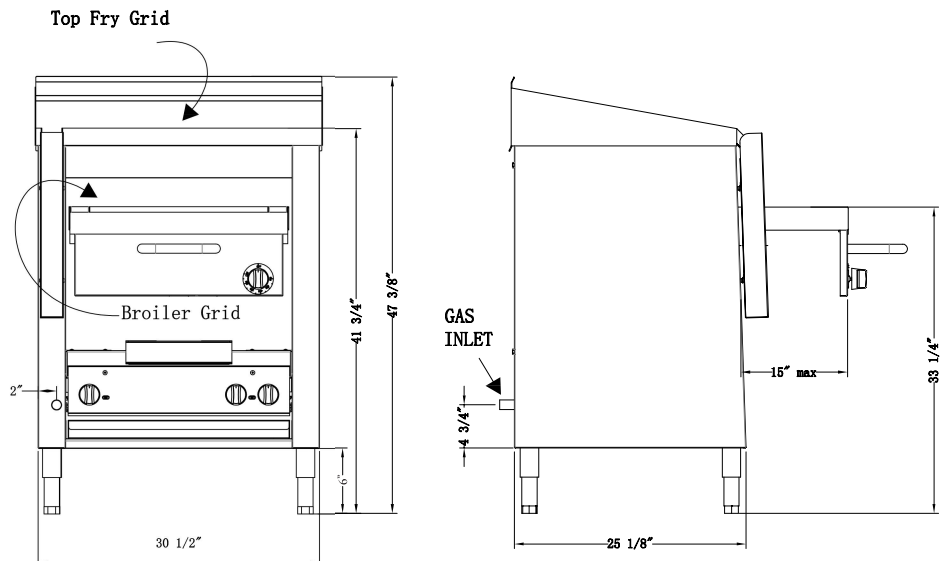

## SPECIFICATIONS:

Overall Width:	31 1/4"
Overall Depth (body):	25"
Overall Height:	47 3/8"
Top Fry Grid Height:	41 3/4"
Broiler Grid Up:	30"
Broiler Grid Down:	26"
Legs (S/S) :	6"
Broiler Grid pulls out:	15"
Broiler Grid:	17 3/4" x 23 1/2"
Top Fry Grid:	22" x 31"
Gas Inlet:	3/4" pipe
Maximum BTU:	102,000
Crated Weight (approx):	500 lbs.

- Heavily insulated, all stainless steel body with stainless steel inner body lining and stainless steel removable side and back liners for easier cleaning
- All welded frame with stainless steel legs and adjustable feet
- Cast iron top burners with ceramic radiants
- Broiler griddle mechanism assembly removable for easier cleaning
- Broiler mechanism moves in and out with ease on our specially designed, heavy-duty ball bearing rollers for loading and unloading of product

## PRODUCT SPECIFICATIONS:

<b>BODY:</b>	18 Gauge #304 Stainless Steel
<b>INNER LINER:</b>	24 Gauge #304 Stainless Steel
<b>GRIDDLE PLATES:</b>	Top -- 1/2" Highly Polished Steel Plate Bottom -- 5/8" Highly Polished Steel Plate
<b>SPLASH:</b>	14 Gauge #304 Stainless Steel
<b>BURNERS:</b>	Top -- Cast Iron w/Ceramic Radiants Bottom -- Stainless Steel
<b>DRIP PAN:</b>	18 Gauge #304 Stainless Steel
<b>VALVES:</b>	Heavy Duty Brass
<b>GAS INLET:</b>	3/4" NPT
<b>GAS PRESSURE:</b>	4.0" Natural, 11.0" Propane (Inches Water Column)

## Available Options:

- Casters (6" Locking)
- Grooved Grid plate
- Chromed Grid plate
- Charbroiled on top as sperate unit
- Castor & Legs extensions 2" Height

*Gas Pressure Regulator is supplied and must be installed Combustible Locations: 6" Clearance sides and back Non-Combustible Locations Only: 0" Clearance sides and back Specify type of gas and altitude if over 2,000 feet*

*Connerton reserves the right, without notice, to make changes and revisions in product specifications, materials and design, which in our opinion will provide better performance, durability and efficiency.*

