

MODELS: CN-SM-36 SALAMANDER BROILER



Designed and Manufactured in USA 

Counter-Top or Wall Mount or Range Mount

▶ STANDARD FEATURES

- Stainless steel exterior and interior
- Welded stainless and aluminized steel chassis
- Equipped with one large heavy-duty pre-mix atmospheric infrared ceramic burners at 35,000 BTU with high efficiency performance.
- Standing pilot ignition system.
- 1 minute pre-heat time
- Heavy-duty chrome plated grid rack and 4 position rack guides
- Removable Stainless-Steel full width spillage pan.
- 3/4" NPT rear gas connection and Standard Regulator - One-year limited parts and labor warranty
- 4" chrome plated legs with Adjustable feet.

▶ ACCESSORIES

- Wall mount with mounting Bracket kit
- Range mount kits are provided with Heavy Duty Connerton Range



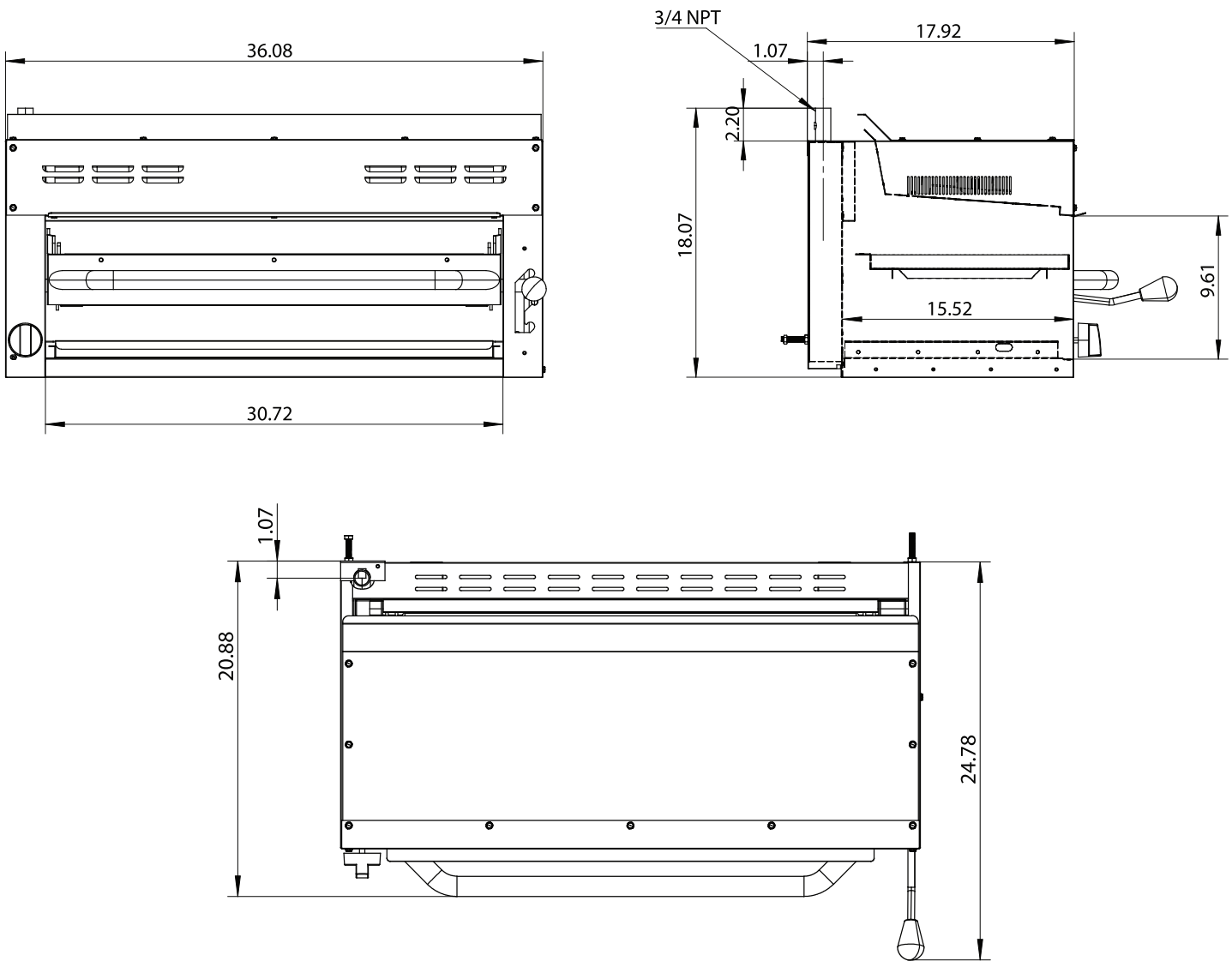

MODELS	GAS TYPE	INTAKE-TUBE PRESSURE (IN.W.C.)	TOTAL BTU B.T.U./H	REGULATOR	EXTERIOR DIMENSIONS (INCH)	NET WEIGHT (LBS)	GROSS WEIGHT (LBS)
CN-SM-36	NG	5	35,000	5" w.c.	36x18x18	92	115
	LP	10	32,000	10" w.c.			