

CEG SERIES THERMOSTATIC CATERING GRIDDLE



Designed and Manufactured in USA 



WELDED #304 STAINLESS STEEL
For easy Cleaning



INTEGRATED "FIRE BOX - FLUE"
Designed for limited Space -
Space Saver



1" HIGHLY POLISHED PLATE
For fast recovery



AVAILABLE OPTIONS:



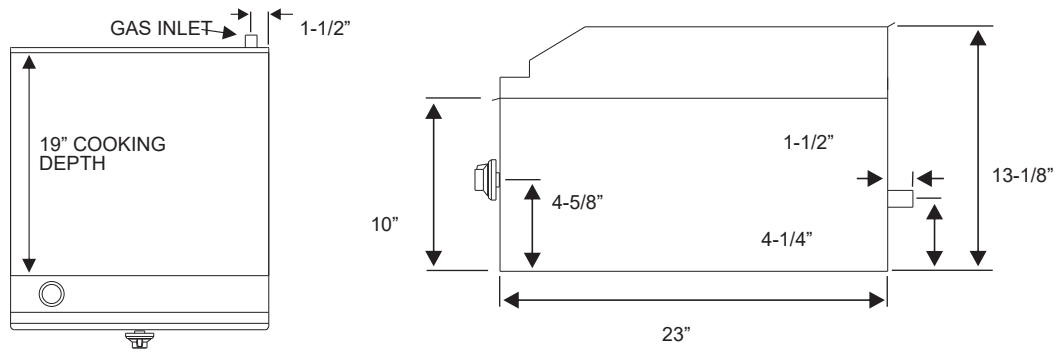







- Stainless Steel Plate Shelf
- Grooved Griddle Plate
- Chromed Griddle Plate
- 4" Legs Accessory
- Floor Model Accessory



MODEL	WIDTH	DEPTH	BTU	BURNERS	WT. (EST)*
CEG-12-T	12"	23"	22,000	1	75
CEG-17-T	17"	23"	22,000	1	100
CEG-22-T	22"	23"	44,000	2	125
CEG-27-T	27"	23"	44,000	2	150
CEG-32-T	32"	23"	66,000	3	175
CEG-37-T	37"	23"	66,000	3	200
CEG-42-T	42"	23"	88,000	4	225
CEG-47-T	47"	23"	88,000	4	250
CEG-52-T	52"	23"	110,000	5	275

*Note: Weight estimates are uncrated

▶ PRODUCT SPECIFICATIONS:

 <p>BODY 18 Gauge Stainless Steel, Fully Welded</p>	 <p>FIRE BOX 16 Gauge Stainless Steel, Welded Body</p>	 <p>FRONT Removable 18 Gauge #304 Stainless Steel Panel</p>	 <p>PLATE 1" Highly Polished Steel Plate</p>	 <p>GUTTER 16 Gauge #304 Stainless Steel</p>	 <p>SPLASH 16 Gauge #304 Stainless Steel, 3" High</p>
 <p>BURNERS 22,000 BTU Tubular Steel</p>	 <p>DRIP PAN 18 Gauge Stainless Steel, Welded</p>	 <p>VALVES Heavy Duty Brass</p>	 <p>GAS INLET ¾ NPT</p>	 <p>GAS PRESSURE 4.0" Natural, 11.0" Propane (Inches Water Column)</p>	

▶ NOTES:

Gas Pressure Regulator is supplied and must be installed Non-Combustible Locations Only:

- 4" Clearance sides and 6" clearance back
- Specify type of gas and altitude if over 2,000 feet



Connerton reserves the right, without notice, to make changes and revisions in product specifications, materials and design, which in our opinion will provide better performance, durability and efficiency.