

# CSG-F4A SERIES NAT/LP GAS 50 LB



**ITEM CSG - F4**



ETL Sanitation



ETL US & Canada



3/4" Gas Connection

## STAINLESS STEEL FLOOR FRYER - 120,000 BTU

### ▶ FEATURES

- All stainless steel tank, door, front, Sides, top, ledge, and header
- Easy to use thermostat for accurate and adjustable temperature between 200-400 degrees Fahrenheit
- 50 lb. fry pot, with an efficient 4 tube burner system, full port drain, and drain pipe extension
- Two nickel chrome wire mesh fry baskets included
- Natural gas, 120,000 BTU

• Width	:	15 1/2 Inches
• Depth	:	30 1/4 Inches
• Height	:	47 1/8 Inches
• Fry Pot	:	Width 14 Inches
• Fry Pot	:	Depth 13 3/4 Inches
• Deep Tank Fry Pot	:	15
• Burner Style	:	Tube
• Cabinet	:	Stainless Steel
• Capacity	:	50 lb.
• Control Type	:	Millivolt
• Gas Inlet Size	:	3/4 Inches
• Number of Fry Baskets	:	2 Fry Baskets
• Number of Fry Pots	:	1 Fry Pots
• Power Type	:	LP or Natural Gas
• Split Pot	:	Without Split Pot
• Temperature Range	:	200-400 Degrees F
• Total BTU	:	120000 BTU
• Type	:	Gas Floor Fryers

# PLAN VIEW OF CSG-F4A SERIES

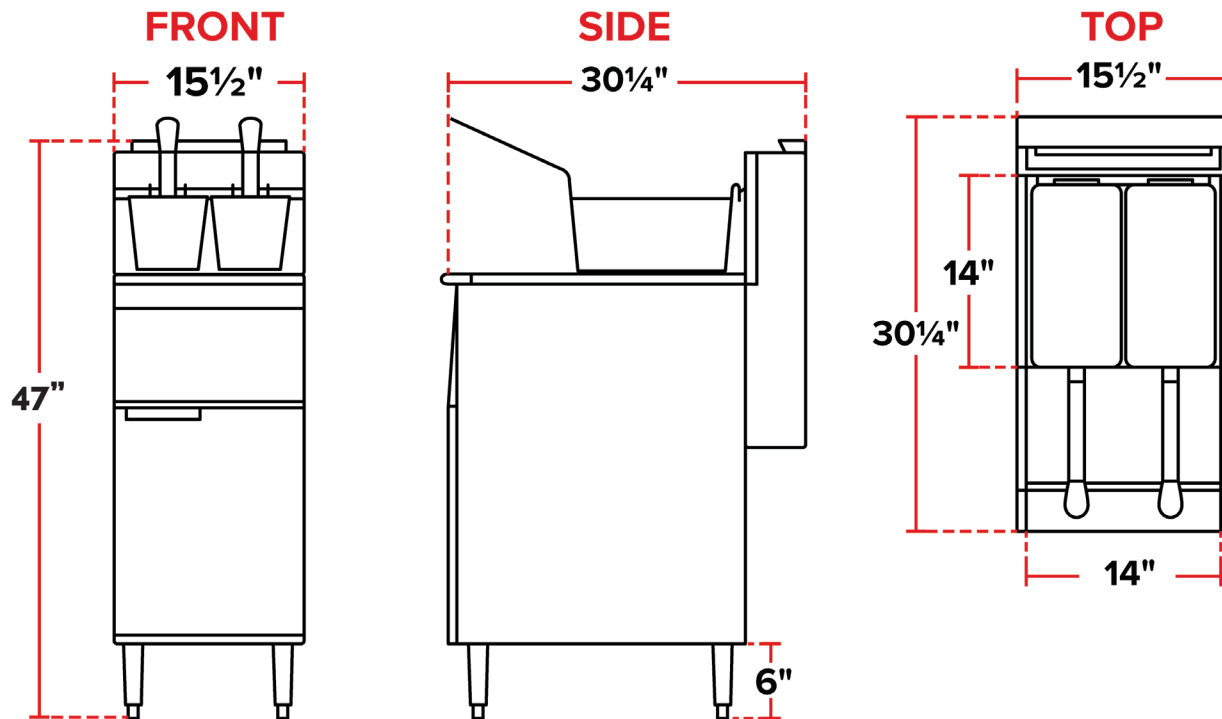

## ▶ NOTES:

A reliable workhorse for any commercial kitchen, the Connerton CSG-F4A 50 lb. stainless steel floor fryer quickly cooks your most popular fried foods, delivering excellent results every time. It utilizes four heat exchange tubes to deliver 120,000 BTUs of power while taking up minimal kitchen space, and its type 430 stainless steel tank ensures outstanding durability and long product life. With very fast recovery time, this fryer is sure to keep up with your busiest hours.

The Connerton CSG-F4A floor fryer features a cool zone in its fry tank, collecting excess

batter and crumbs and allowing them to sink to the bottom of the tank for easy cleaning. A 1-1/4" ball type full port drain lets you quickly remove used oil, and an Invensys thermostat allows temperature adjustment from 200 to 400 degrees Fahrenheit. This fryer also has a stainless steel door, front, sides and header while its heavy duty frame ensures a strong structure. A convenient tube rack supports the two included nickel chrome wire mesh fry baskets, and 6" adjustable legs make it easy to clean the floor underneath.



This product can expose you to chemicals including lead, which are known to the State of California to cause cancer, birth defects, or other reproductive harm. For more information, go to [www.p65warnings.ca.gov](http://www.p65warnings.ca.gov).