

CSF-24 SERIES SHALLOW FRYER

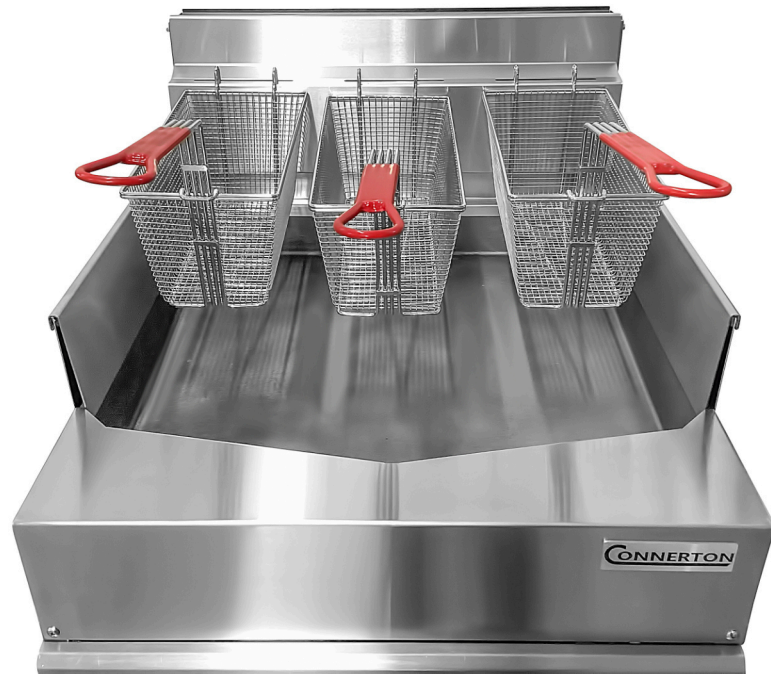

Designed and Manufactured in USA 

MULTI PURPOSE COOKING EQUIPMENT PERFECT FOR BOTH FRYING AND GRILLING.

DESCRIPTION:

The Thick Cast Iron Frying Tank contains heat for quick recovery and efficiency. This unique Fryer uses both the oil and surface contact to cook and sear as well as deep frying. Food products can be Deep Fried or Grilled by using less oil and allowing for surface contact and quick searing.

The fat soluble vitamins and fatty acids in cooking oils show comparatively reasonable stability when they are used for shallow frying rather than deep frying.

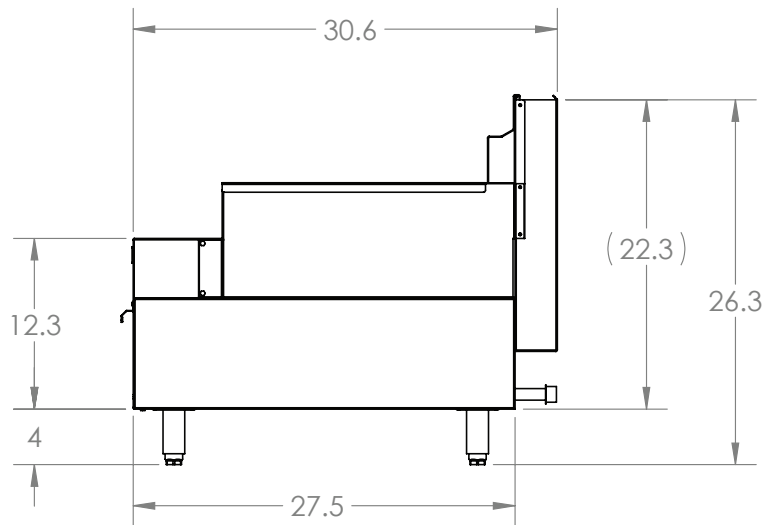
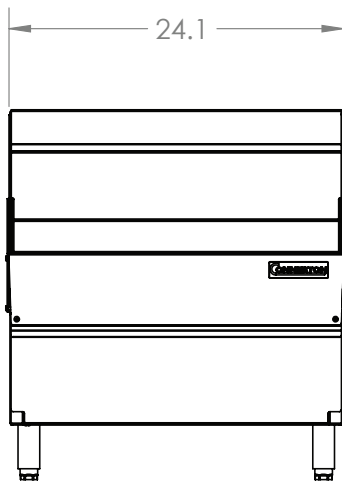
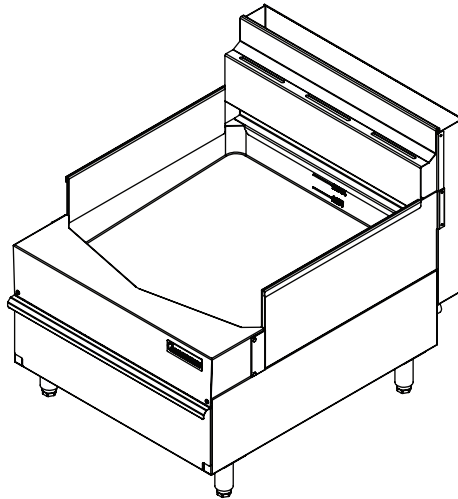

CONNERTON COUNTER TOP SKILLET FRYER'S GENERAL SPECIFICATION:

- Number of Burners = 2
- 30,000 BTU / Burner or Total of 60,000 BTU
- Thermostatic Control – Snap Action with Millivolt Gas Valve
- All Stainless-Steel Welded Body/Frame
- All exterior panels made of Stainless-Steel
- Half-Inch Thick Cast Iron Frying Tank



Connerton reserves the right, without notice, to make changes and revisions in product specifications, materials and design, which in our opinion will provide better performance, durability and efficiency.