

CSG-Auto SERIES NAT/LP GAS 50 LB



ETL Sanitation



ETL US & Canada



3/4" Gas Connection

SMART TOUCH FLOOR FRYER - 120,000 BTU

▶ FEATURES

- All stainless steel tank, door, front, Sides, top, ledge, and header
- Smart Touch control for precise temperature and consistent frying quality
- Auto-lifting baskets for fully unattended frying.
- Idle mode for energy and cost savings.
- Alarm notification when frying is complete.
- Multiple built-in frying programs.
- Large touch screen for easy operation
- Natural gas, 120,000 BTU

Width	: 15.5 Inches
Depth	: 30.4 Inches
Height	: 45.3 Inches
Burner Style	: Tube
Cabinet	: Stainless Steel
Capacity	: 50 lb
Control Type	: Digital Control/Smart Touch
Gas Inlet Size	: 3/4 Inches
Number of Fry Basket	: 2 Fry Baskets
Number of Fry Pots	: 1 Fry Pots
Gas Type	: LP or Natural Gas
Temperature Range	: 200-400 Degrees F

PLAN VIEW OF CSG-F5A SERIES

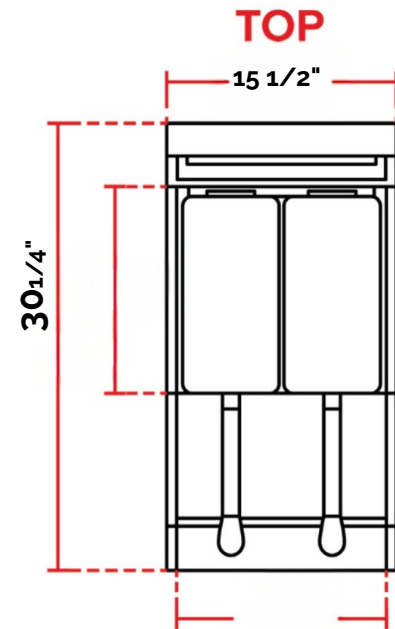
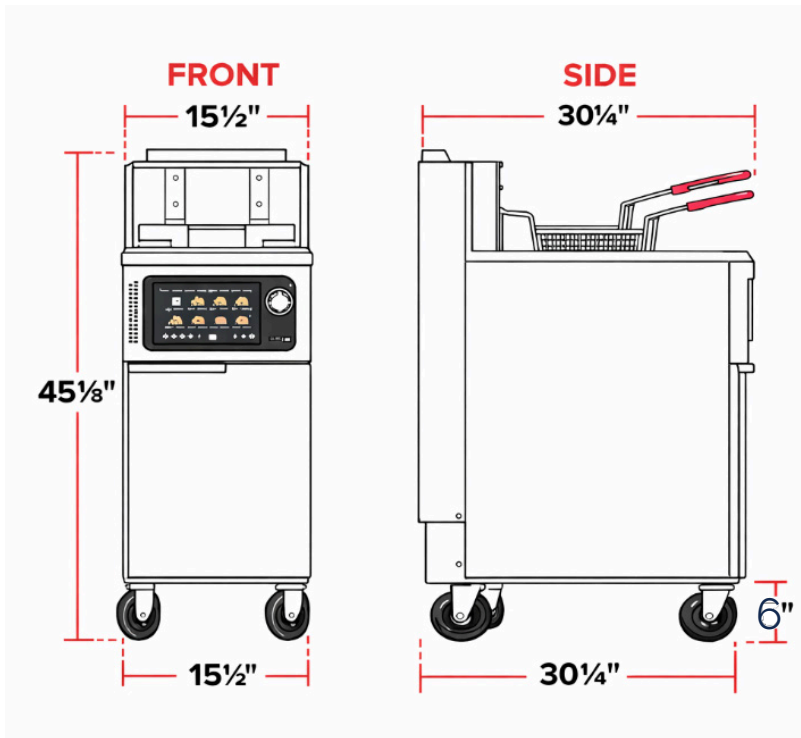

▶ NOTES:

A reliable workhorse for any commercial kitchen, the Connerton CSG-Auto 50 lb. stainless steel Smart Touch floor fryer quickly cooks your most popular fried foods, delivering excellent results every time. It utilizes four heat exchange tubes to deliver 120,000 BTUs of power while taking up minimal kitchen space, and its type 430 stainless steel tank ensures outstanding durability and long product life. With very fast recovery time, this fryer is sure to keep up with your busiest hours.

The Connerton CSG-F5A floor fryer features a cool zone in its fry tank, collecting excess

batter and crumbs and allowing them to sink to the bottom of the tank for easy cleaning. A 1-1/4" ball type full port drain lets you quickly remove used oil, and an Invensys thermostat allows temperature adjustment from 200 to 400 degrees Fahrenheit. This fryer also has a stainless steel door, front, sides and header while its heavy duty frame ensures a strong structure. A convenient tube rack supports the two included nickel chrome wire mesh fry baskets, and 6" adjustable legs make it easy to clean the floor underneath.



This product can expose you to chemicals including lead, which are known to the State of California to cause cancer, birth defects, or other reproductive harm. For more information, go to www.p65warnings.ca.gov.